

# *blueGel*<sup>™</sup> Electrophoresis System User's Guide

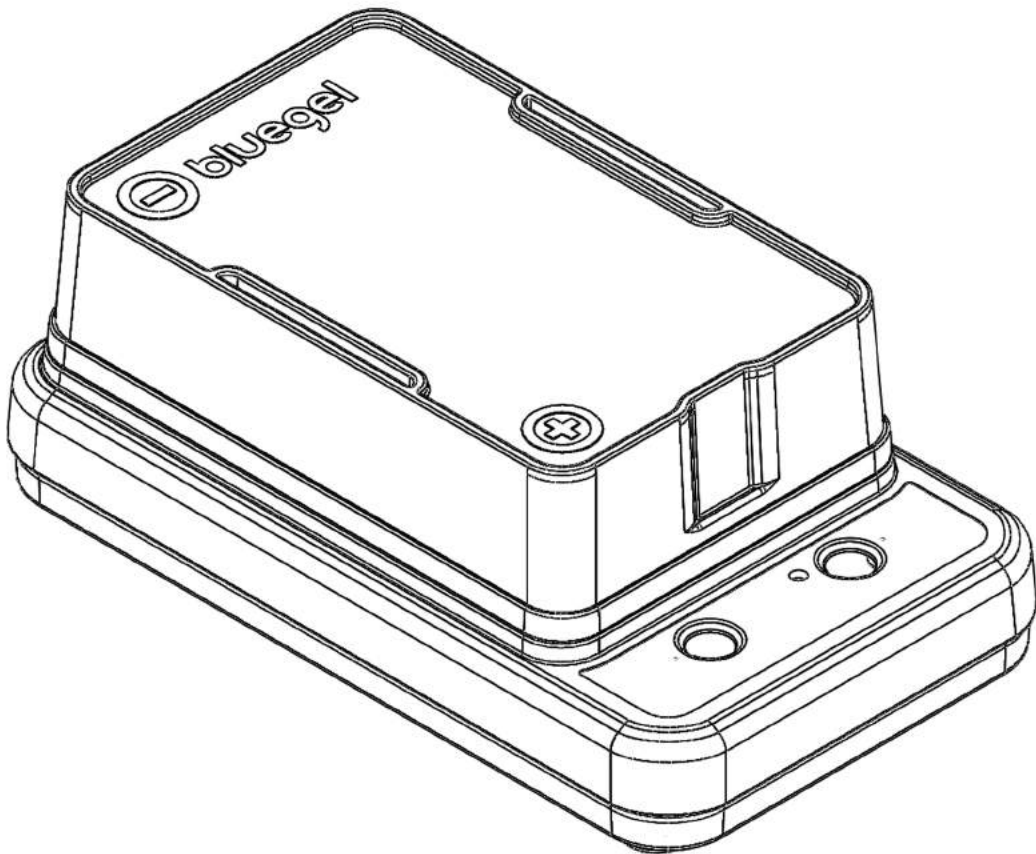

**bluegel**  
by minipcr

Integrated electrophoresis  
and visualization system

minipcr

# WARRANTY

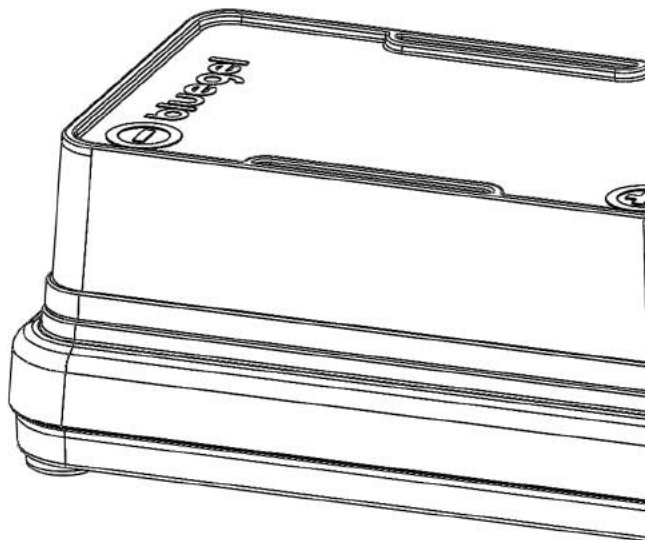

This Limited Warranty covers defects in materials and workmanship for a period of 12 months from the date of purchase under the following conditions:

This Limited Warranty covers the original purchaser of the Product and shall not extend in its validity to third parties without the written agreement of Amplify LLC ("Amplify").

This Limited Warranty covers only the Product and any original accessories provided with it. It excludes software, documentation, consumables, or related items.

This Limited Warranty will maintain its validity only as long as the Product is operated in the manner, conditions, and with the care described in its User's Guide or Manual. This Limited Warranty will be voided by improper or unauthorized maintenance of the Product, or by improper attachment of electrical adapters and power supplies not supplied by Amplify or its authorized representatives.

Amplify will repair or replace any defective items upon factory inspection of the item claimed. Amplify will cover shipping charges if the claim is initiated within 30 days from purchase. After 30 days from the date of purchase, end users of the Product will be responsible for shipping charges to and from the Amplify facility for assessment and repair under the terms of this Limited Warranty. This Limited Warranty does not cover wear and tear to components resulting from normal use of the Product, nor does it cover failures caused by incorrect use, negligence, alterations, or damage caused by intentional or accidental misuse of equipment. This Limited Warranty also excludes damage caused during any shipment/transport/movement of the product following its initial receipt by the customer.

Amplify's sole liability, under this Limited Warranty, for failure to repair or replace blueGel™ products after a reasonable number of attempts, is limited to the replacement of the Product or, at Amplify's sole discretion, the refund of the original purchase price of the Product.

## LICENSED TECHNOLOGY

Licensed under US patents 6198107, 6512236, 6914250 and EP 0965034.

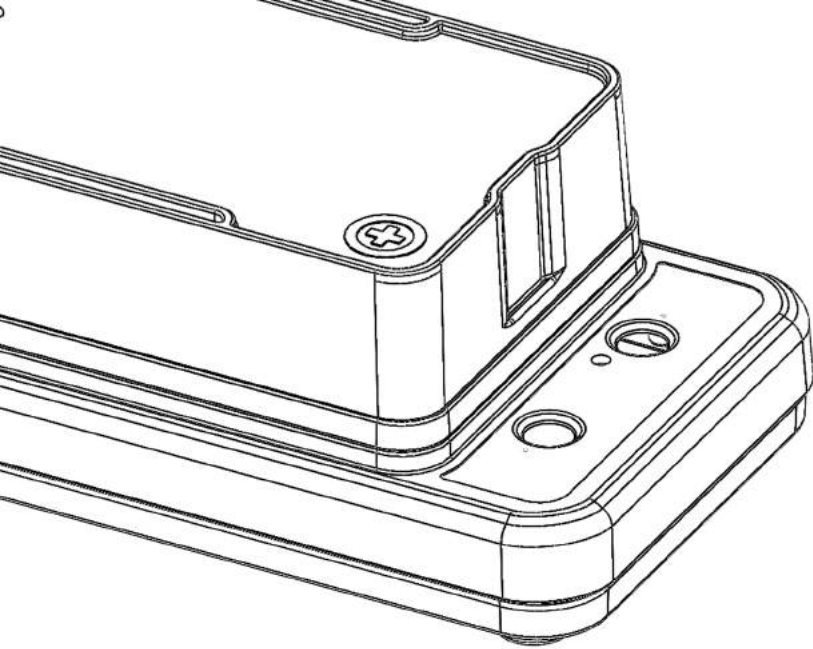

# FEATURES



## **Fast and Safe Electrophoresis**

UL and CE marked 48v power supply. Automatic current shut-off when cover is not present. Platinum and stainless steel electrodes on cover for safety. Buffer chamber designed for maximum run rate

## **Safe Blue Light Illumination**

High intensity blue LED illuminator panel. Blue diffuser for even gel illumination. Amber filter integrated in cover for direct visualization. View results within minutes

## **Casting System**

Save on reagents: 20 ml gels and 25 ml buffer. 60 x 60 mm gel tray with one or two rows of combs. Two double-sided combs with choice of 9 and 13 wells

## **Easy to Operate and Store**

Intuitive two-button operation: one for Run, one for Light. 3 x 9 inch footprint, 4 inches high. Storage pouch included

## **Fold-a-View™ Documentation Hood**

A portable, foldable darkroom. Image capture even in brightly lit rooms.

# COMPONENTS

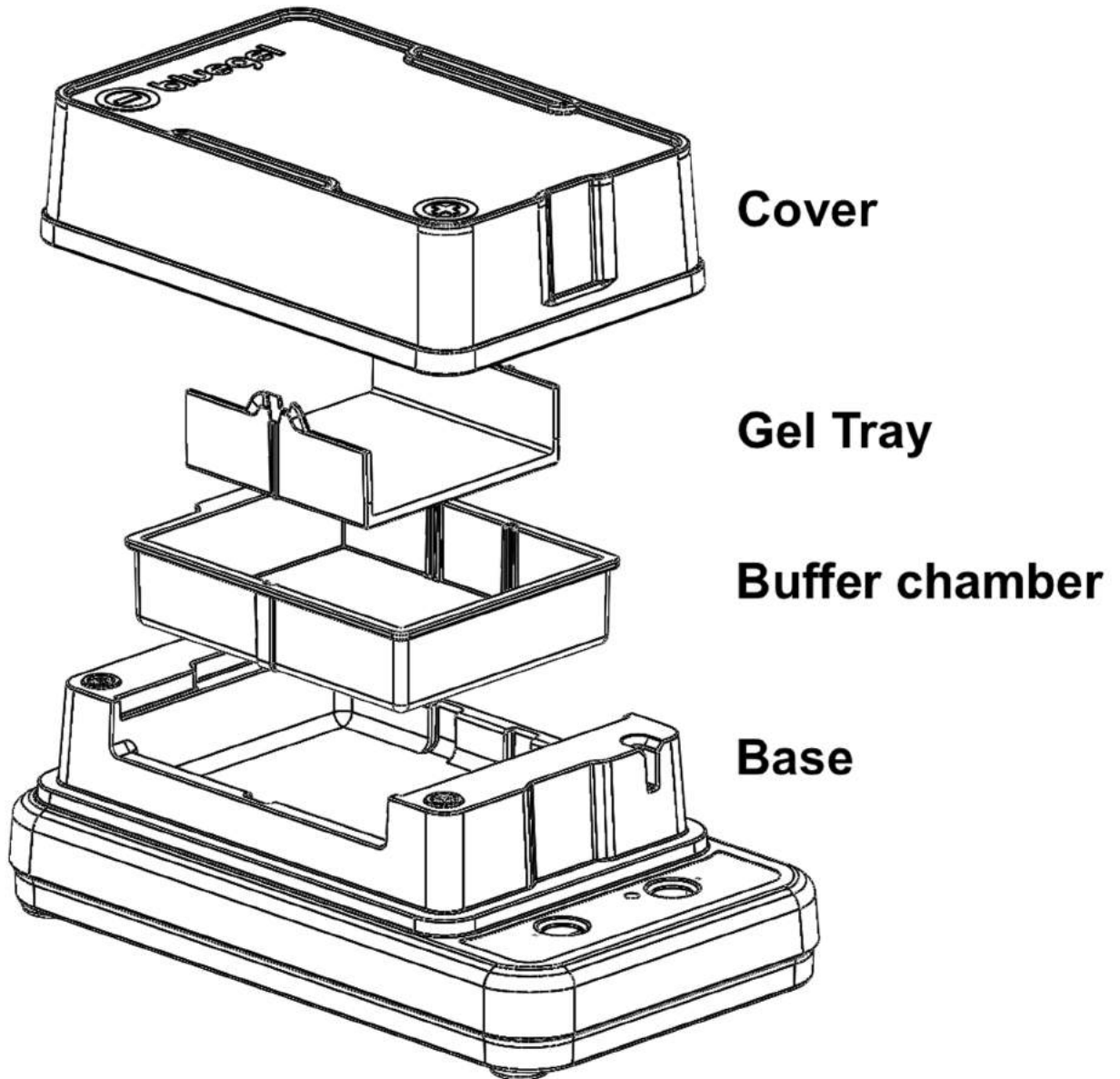

# COMPONENTS (cont.)

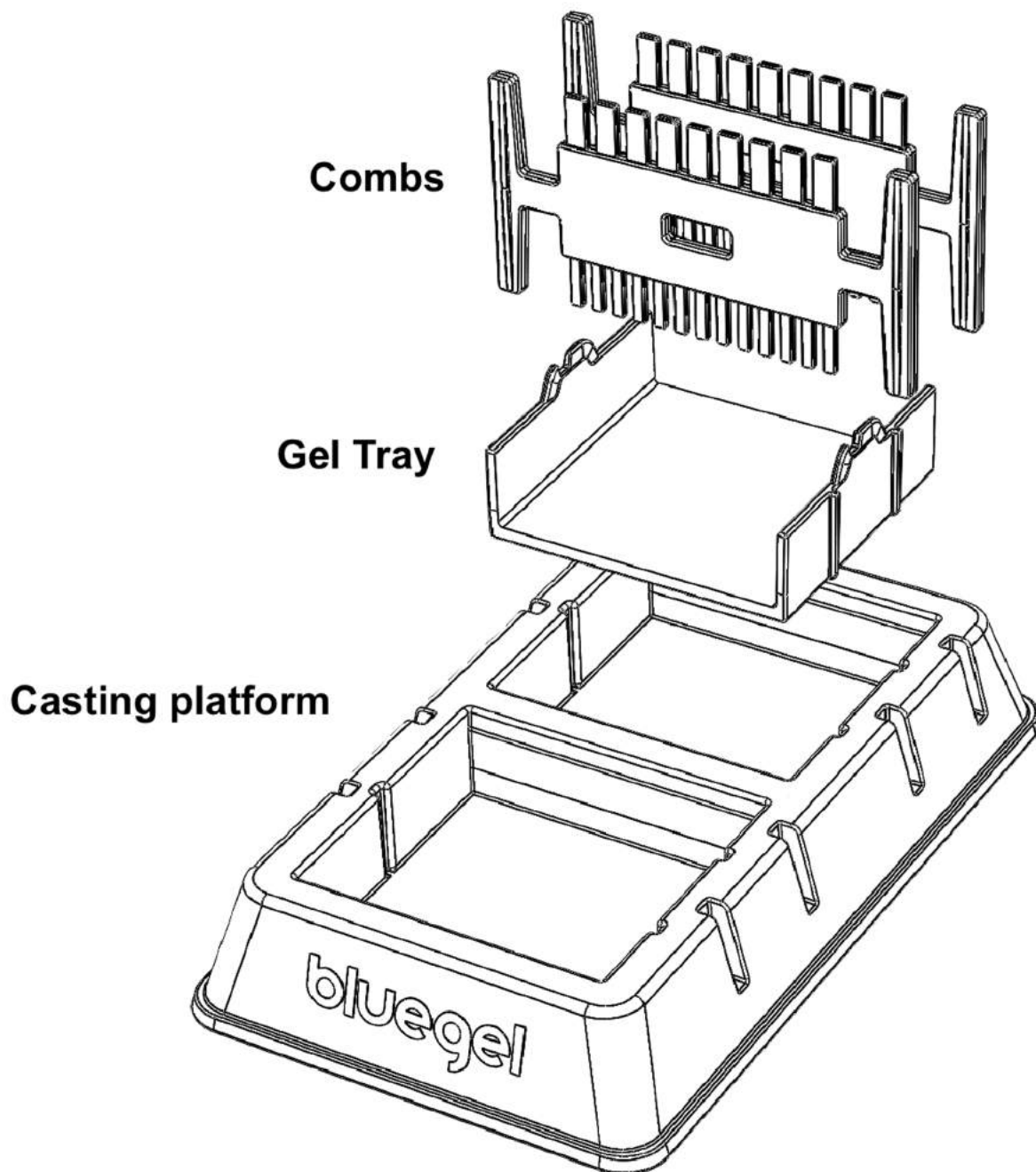

# COMPONENTS (cont.)

Comb storage under casting platform

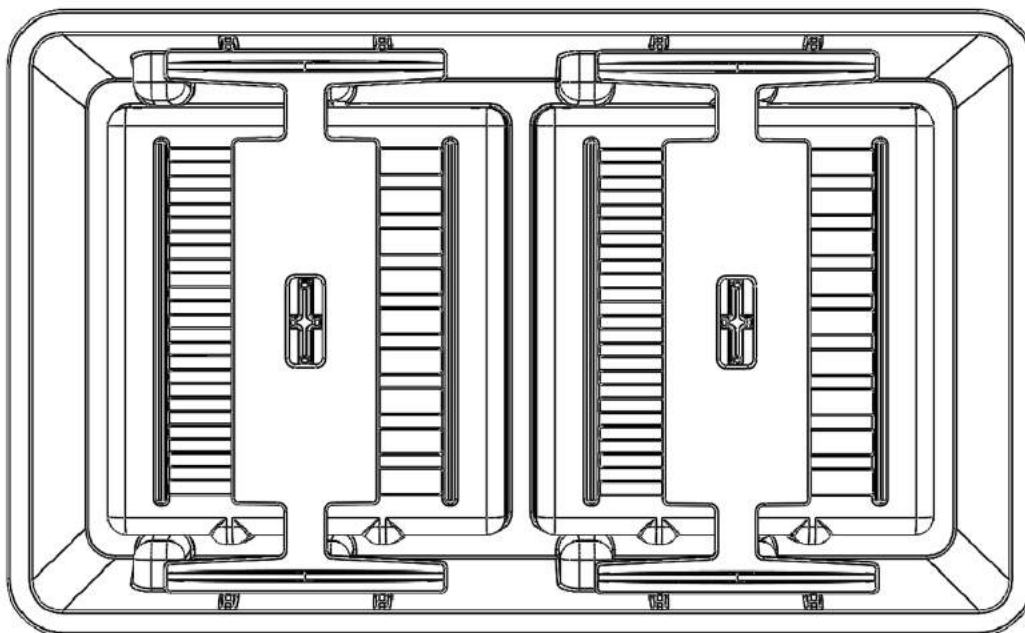

## SYSTEM INCLUDES

- |                      |                               |
|----------------------|-------------------------------|
| (1) Cover            | (2) Two-sided combs           |
| (2) Gel trays        | (1) Power supply              |
| (1) Buffer chamber   | (1) ClearView™ Spray          |
| (1) Base             | (1) Lens cleaning cloth       |
| (1) Casting platform | (1) Fold-a-View™ Imaging Hood |
|                      | (1) Carrying pouch            |

# DIRECTIONS FOR USE

## CASTING A GEL

1. Place the gel tray inside the casting platform. Place on a level surface to ensure uniform gel thickness.
2. Determine the percentage gel to make:

Size of DNA to separate	Gel percentage (%)	Agarose (g)	1x TBE* (ml)
600bp to 12kb	0.8	0.16	20
500bp to 10kb	1	0.2	20
400bp to 7kb	1.5	0.3	20
200 bp to 5kb	2	0.4	20
60bp to 2kb	3	0.6	20

*Note: if using two rows of wells (two combs) resolution will be reduced due to shorter separation distance.*

\* Warning: blueGel™ is designed to work best with 0.5 to 1.0X TBE (Tris Borate EDTA) buffer. Use of other buffers such as TAE or SB may result in impaired performance.

3. Weigh the desired amount of agarose according to the chart above and add it to a 100ml size flask (or larger) containing 20ml of 1x TBE electrophoresis buffer. Mix well by swirling.

*Tip: If pouring more than one gel, agarose and buffer quantities can be multiplied by the number of gels to be poured. Increase heating time by ~15 sec per additional gel and use a larger flask*

4. Place flask in microwave (~30 seconds) or on a hot plate until all the agarose is dissolved. The agarose/buffer mix is ready when no agarose particles are visible upon swirling.

*CAUTION: liquid may bubble over the mouth of the flask and cause burns. Handle with care using protective equipment.*

5. Let agarose/buffer mix cool for ~2-3 minutes and add 2µl of Gel Green™ DNA stain 10,000X stock (1µl per 10ml of TBE). Swirl well to mix. See Appendix B for additional DNA staining dyes that work with blueGel™.

# DIRECTIONS FOR USE

## CASTING A GEL (cont.)

6. Place the comb in the top slot and pour all the agarose/buffer mix into the gel tray. To double the well capacity add a second comb in the middle of the gel tray. Each comb will form either 9 or 13 wells. Remove any air bubbles using a disposable micropipette tip.

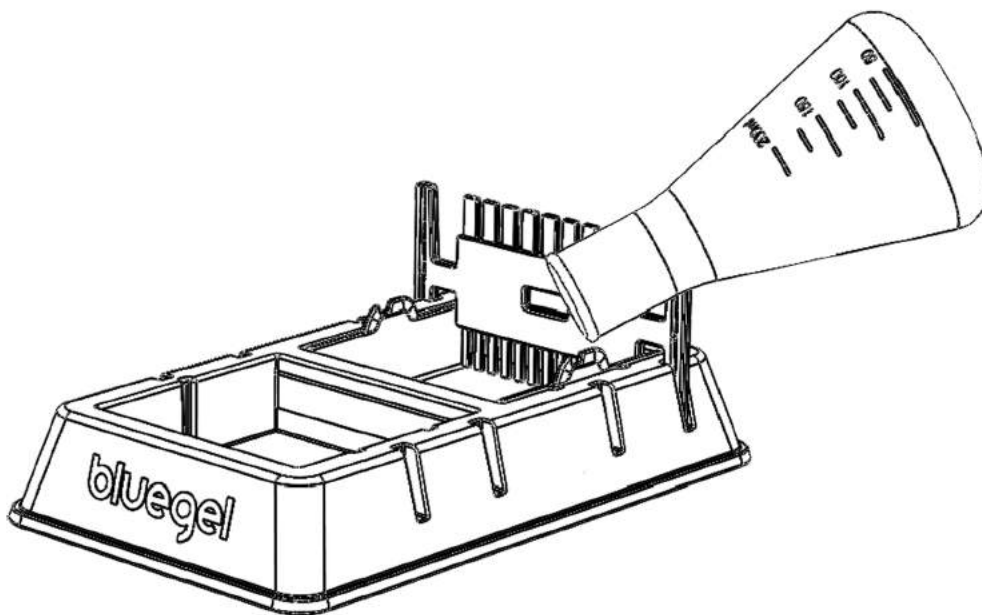

7. Let gel stand for ~10 minutes until completely set. For faster set time place the casting platform with the gel in a refrigerator. Do not disturb the gel during this time.
8. After the gel has solidified, remove comb/s gently by pulling straight upward.
9. Remove the gel tray from the casting platform. If a small amount of gel has formed underneath the gel tray, wipe it off and discard it.

*TIP: We recommend using gels immediately after casting. Unused gels can be kept in the refrigerator (4°C) for 5 days if they are kept moist and protected from light (place gel inside a resealable zip bag with a paper towel saturated in running buffer, and covered in foil). DNA gel stains differ in stability and may fade if gels are stored – refer to the manufacturers' recommendations*



# DIRECTIONS FOR USE

## RUNNING A GEL

1. Place the gel tray containing a gel in the buffer chamber and place the buffer chamber inside the blueGel™ base. The wells should be closest to the (-) end.
2. Add 30 ml of 1x TBE buffer in the buffer chamber. The buffer should just cover the agarose gel.

*CAUTION: Do not overfill the gel chamber as it may overflow when the cover is placed over the gel.*

3. Remove air bubbles (if any) trapped between the gel and the gel tray, or between the gel tray and the buffer chamber
4. Load the DNA samples in the wells using a micropipette.

9-well combs hold up to 20µl

13-well combs hold up to 10µl

Be careful not to puncture the gel with the micropipette tip.

Note: The DNA samples should contain loading dye.

*Recommended: To prevent fogging during electrophoresis, spray 1 pump or less of ClearView Spray™ inside the orange cover, between the electrodes. Spread to an even coat using a microfiber cloth. Wipe gently, do not rub clean.*

5. Place the orange cover on the blueGel™ base. The cover contains the electrodes and will only fit in one direction, with the (+) electrode positioned to attract the negatively charged DNA.
6. Press the power button  to start the run. The green LED indicator located next to the power button should light up. Small bubbles will form near the electrodes

# DIRECTIONS FOR USE

## RUNNING A GEL (cont.)

*NOTE: For safety, the power won't turn on if:*

- a. The cover is not correctly placed on the base, and electrodes are not making contact*
- b. There is no buffer in the buffer chamber*
- c. Using the incorrect buffer (too diluted or too concentrated)*

7. At any time during the run press the lightbulb button  to visualize the DNA. The orange cover filters the excess blue light allowing easier visualization of the fluorescence emitted by DNA.

## DOCUMENT THE RUN

To document turn the blue light on and take a picture with a smartphone, tablet or other camera device.

Tip: If DNA is not easily visible, dim or turn off ambient light. To document gels in bright ambient light, use the supplied Fold-a-View™ photo documentation hood. Pop up the Fold-a-View following the instructions on its side and place it on the blueGel™ orange cover, sliding it down until it fits snugly around the cover's edges. Place your camera on top, and align the camera lens with the circular opening on the Fold-a-View™.

Note: if wiggling motion when placing the Fold-a-View™ disrupts electrode contact between the blueGel™ cover and base, press the run button again and ensure the green pilot light indicating electrophoresis run remains on.

If needed, softly wipe condensation off the inside of the orange cover with the supplied lens cleaning cloth to improve visibility.

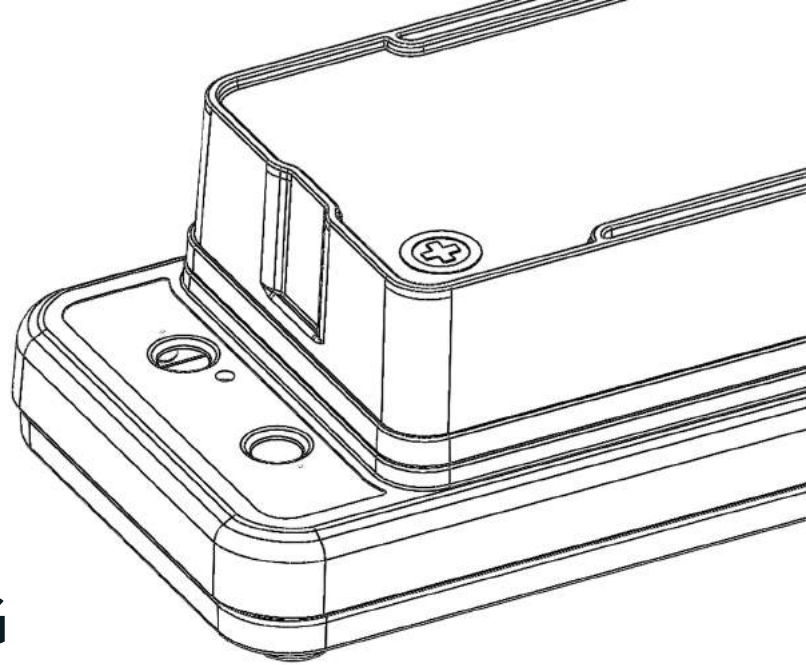

## TROUBLESHOOTING

- Can't find combs: combs are stored in the back of the casting platform
- Gel tray won't fit inside the buffer chamber: ensure guides at the sides of the gel tray and casting platform are aligned.
- Buffer chamber won't fit inside the base: ensure the chamber is being inserted in the correct orientation, with the tab towards the back of the unit
- Orange cover won't fit: ensure proper orientation.
- Run won't start (LED indicator not on): check electrode contact and alignment between cover and base. Check that the running buffer is making contact with the electrodes. Confirm that you are using the correct running buffer.
- Condensation on cover: apply ClearView™ before use or use lens cleaning cloth to gently wipe off.
- Gel edges shrinking after prolonged runs: ensure you are using 0.5X or 1X TBE buffer

# CARE OF YOUR



## ELECTROPHORESIS SYSTEM

Please follow these recommendations to maintain your blueGel™ system in optimal working condition

- Rinse the casting platform, combs, gel tray, buffer chamber and cover in distilled water after each use. Do not wipe or handle platinum wire. Air dry
- Never submerge the blueGel™ base in water
- Do not use ethanol or organic solvents to clean parts
- Handle the buffer chamber, gel tray and cover with care to protect from scratching
- Always store blueGel™ components in the carrying pouch



## ELECTROPHORESIS SYSTEM

### SPECIFICATIONS AND OPERATING CONDITIONS

- High Intensity blue LED panel
- Input voltage 100-240v AC~47-63Hz, 0.58A Max
- Output 48V DC 0.5A 24W Max
- Indoor use only
- Operating temperature 9°C - 30°C, max. humidity 70%

APPENDIX A – BLUEGEL™ ACCESSORIES AND REPLACEMENT PARTS  
AVAILABLE AT [WWW.MINIPCR.COM](http://WWW.MINIPCR.COM)

Description	Part No.
Gel Green™ DNA stain	RG-1550-01
Agarose, 20g	RG-1500-02
TBE Buffer, 20X	RG-1502-02
blueGel™ base	QP-1500-05
blueGel™ cover	QP-1500-06
blueGel™ casting platform	QP-1500-07
blueGel™ gel tray	QP-1500-08
blueGel™ comb	QP-1500-09
blueGel™ buffer chamber	QP-1500-10
blueGel™ power supply	QP-1500-11
blueGel™ PhotoView carrying pouch	QP-1500-12
blueGel™ Lens cleaning cloth	QP-1500-13
Fold-a-View™ photo documentation hood	QP-1500-14

APPENDIX B – DNA GEL STAINS COMPATIBLE WITH BLUEGEL™

DNA gel stain	Manufacturer
GreenView Plus, GreenView Ultra	Applied BioProbes
GelGreen	Biotium
SybrSafe or SybrGreen	ThermoFisher
EvaGreen	Jena Bioscience