

CORE SERIES

(P.N. 3.08.6.6.9539, Revision B4, April 2012)

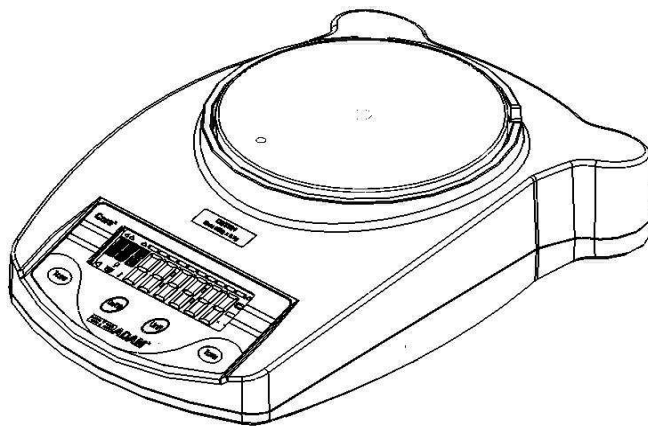

Easy Reference:

Model name of the balance:	
Serial number of the unit:	
Software revision number (Displayed when power is first turned on):	
Date of Purchase:	
Name of the supplier and place:	

1.0	CONTENTS	
1.0	CONTENTS	2
2.0	SET UP	3
2.1	UNPACKING AND SETTING UP YOUR BALANCE	3
2.2	INSTALLING BATTERIES	4
2.3	OVERVIEW - DISPLAY / KEY BOARD	4
2.4	LOCATING AND PROTECTING YOUR BALANCE	6
2.5	STORING WHEN NOT IN USE	7
3.0	BASIC OPERATION.....	8
3.1	TURNING ON THE BALANCE	8
3.2	ZEROING / TARE	8
3.3	WEIGHING.....	9
3.4	WEIGHING UNITS.....	9
4.0	PARAMETERS	10
4.1	AUTO POWER OFF.....	10
4.2	SETTING THE BACKLIGHT	11
4.3	ENABLING THE WEIGHING UNITS	11
5.0	CALIBRATION.....	13
6.0	TROUBLE SHOOTING.....	14
6.1	ERROR MESSAGES	14
6.2	REPLACEMENT PARTS AND ACCESSORIES	15
7.0	SPECIFICATIONS.....	16
8.0	WARRANTY STATEMENT	17

2.0 SET UP

2.1 UNPACKING AND SETTING UP YOUR BALANCE

- 1) Remove the shipping protection screw and round cover as shown below using the Allen key supplied in the plastic bag. (It is advisable to keep the shipping protection screw and the round cover along with the packing box for using during shipping to another location in future).

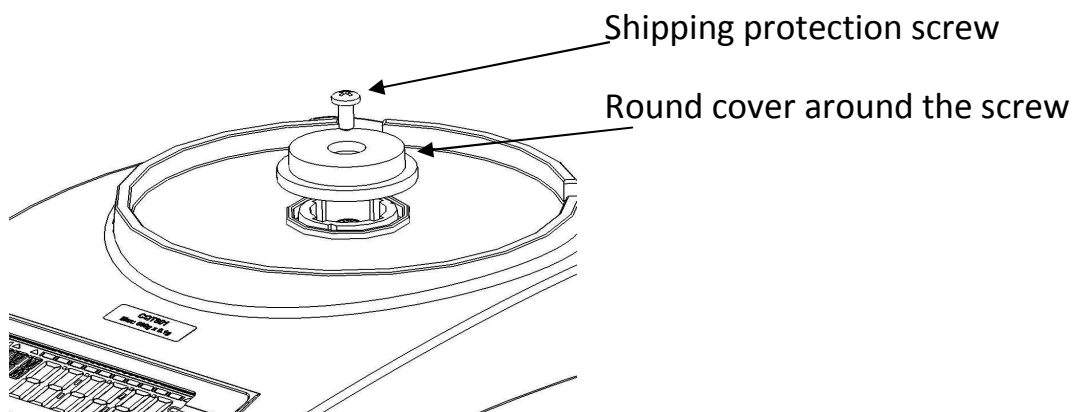

- 2) Place the pan (which comes separately packed) in the receptacles on the top cover.

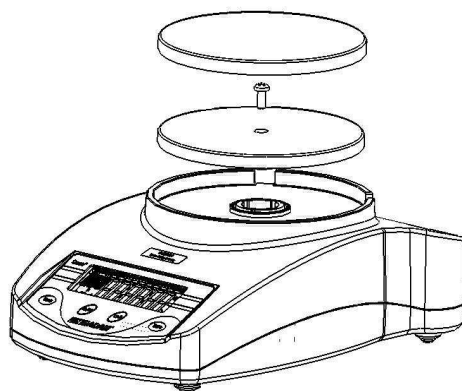

Gently place the plastic pan support into the receptacle and secure with the screw supplied in the plastic bag. Be careful when putting the screw in that you do not use too much force as it can damaged the loadcell. You should just be able to use light force to secure the screw.



- 3) Place the stainless steel pan on top of the plastic pan.
- 4) Place the balance on a firm and flat surface for accurate weighing.

2.2 INSTALLING BATTERIES

Remove the battery compartment cover and insert six batteries (R6P/LR6 /AA size) into the battery compartment.

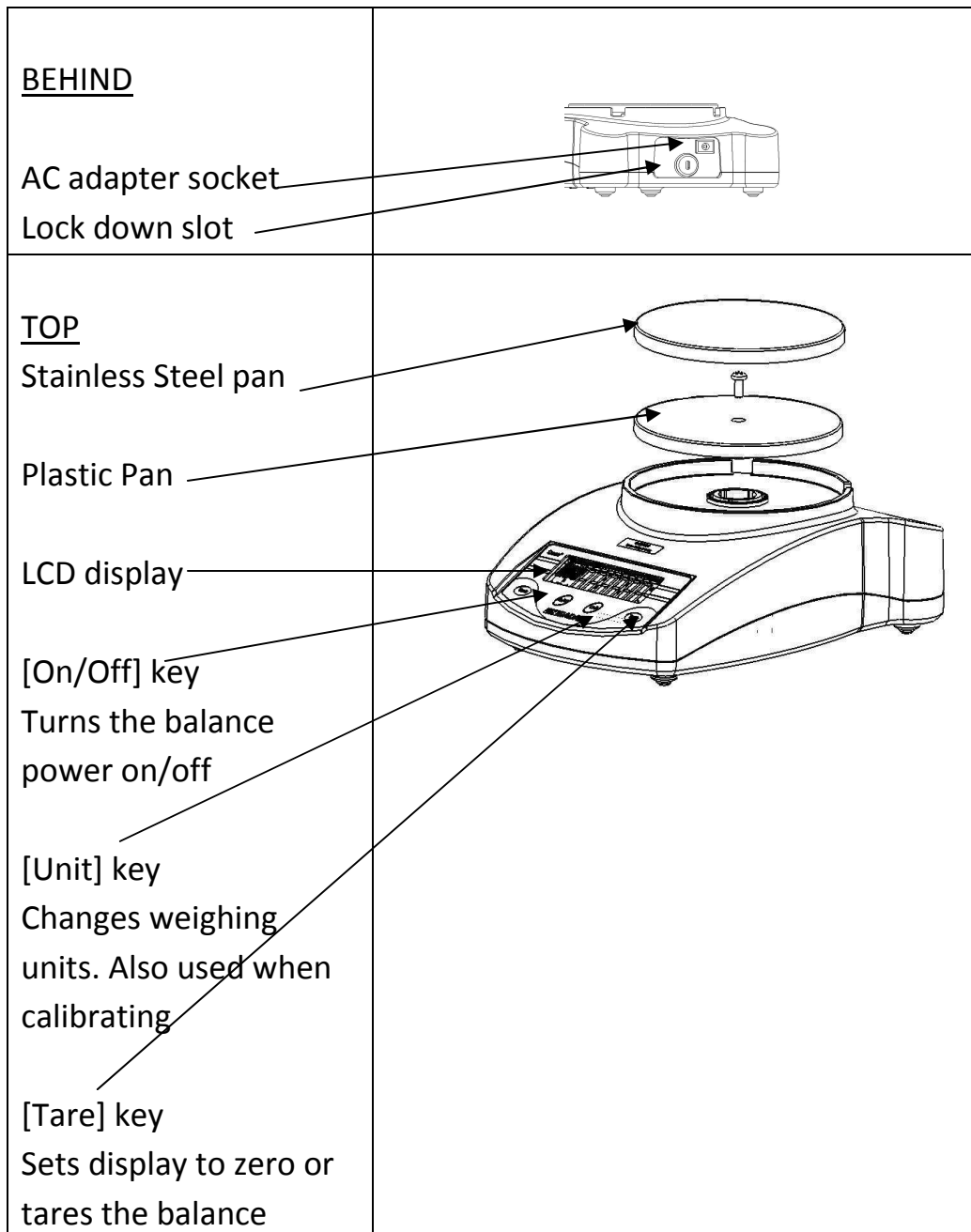
2.3 OVERVIEW - DISPLAY / KEY BOARD

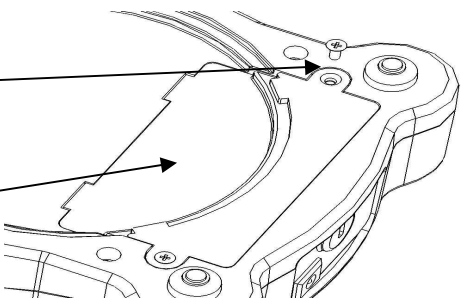

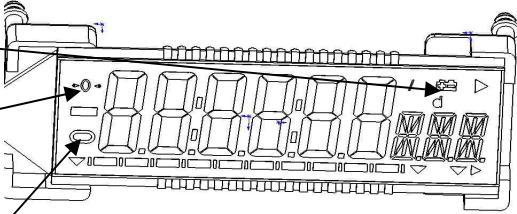
<p><u>BOTTOM</u></p> <p>Battery compartment screws</p> <p>Battery compartment cover</p> <p>Batteries are not included</p>	
<p><u>DISPLAY</u></p> <p> battery indicator</p> <p>ZERO indicator Indicates when the balance zero is correct.</p> <p>STABLE indicator Indicates when the reading is stable.</p>	

2.4 LOCATING AND PROTECTING YOUR BALANCE

In order to keep your balance functioning at its best we suggest that you do the following:



Avoid extremes of temperature. Do not place in direct sunlight or near air conditioning vents.



Make sure the balance is located on a strong table and free from vibration.

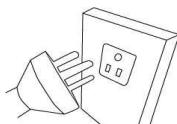

Avoid unstable power sources. Do not operate near large users of electricity such as welding equipment or large motors. Do not leave batteries in the balance if you are not using it for a long time.

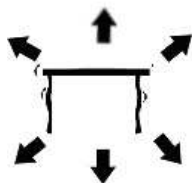

Keep free from vibration. Do not place near heavy or vibrating machinery.

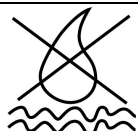

Avoid high humidity that might cause condensation, and keep away from direct contact with water.



Do not place near open windows, air-conditioning vents or fans that may cause a draft and unstable readings.

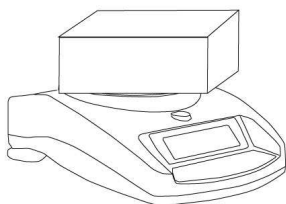

Keep the balances clean, and do not stack material on the balance when it is not in use. The Core has a stacking feature allowing more than one unit to be stacked on top of each other. For more details on this see the section on storing.

2.5 STORING WHEN NOT IN USE

If you have any of the Highland™ series or Core Balance™ lines you can store them easily on top of each other. This helps to save space and protect them from damage.

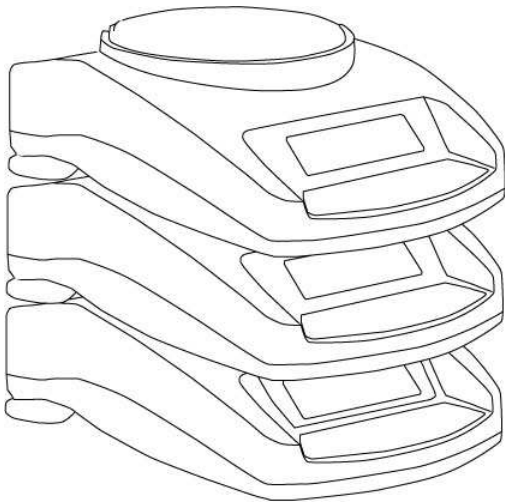

Without Shield

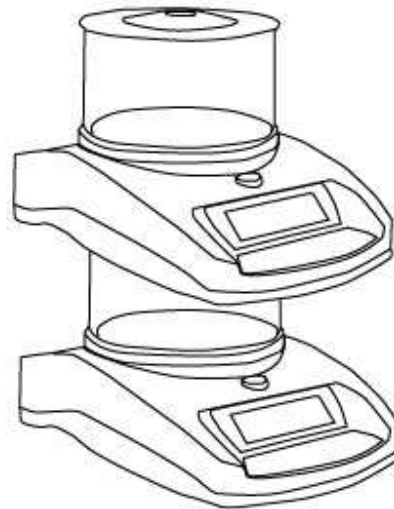

With Shield

Note: Only 4.7" / 120mm \varnothing pan size models can be stacked for storage. Core models with 5.7" / 145mm \varnothing may be stacked at the top of the pile but machines cannot be stacked on top of them due to the larger pan size.

3.0 BASIC OPERATION

3.1 TURNING ON THE BALANCE

Plug in the unit using the AC adapter or power from the batteries.

- 1) Press the On/Off button and the balance will automatically show **Cgt-1.0 Cgt** then count from 0 to 9 for a few seconds, and show the voltage **XXVol** where x.x is the voltage of the battery or the AC adapter. Finally it will display "0.00" along with the last selected weighing unit, Stable symbol, and Zero symbol.
- 2) The balance is ready to be used.
- 3) To turn the balance off after use press the **[on/off]** key again. There is an auto power-off function that will automatically turn the unit off, this can be set in the parameters section.

3.2 ZEROING / TARE

You can press the **[Tare]** key to set a new zero point. Zero will be set if the reading on the balance is less than 3% of the balance's capacity. This may be necessary if the weight is not reading zero with nothing on the pan. The zero indicator will show up in the top left corner of the LCD.

If you are using a container to weigh then you can place this on the platform and press the **[Tare]** key, providing the container weight is more than 3% of the maximum capacity of the balance, the display will show zero and **NET** will light up on the display. You can then weigh your object in the container. Tared weight is subtracted from the total balance's capacity.



Note: When the container is removed a negative value will be shown. If the balance was tared just before removing the container, this value is the gross weight of the container plus all items inside the container which were removed.

3.3 WEIGHING

To determine the weight of a sample, first tare an empty container (if used), then place the sample in the container. The display will show the weight and the unit of weight currently in use. The stable indicator will light up when the reading is stable.

3.4 WEIGHING UNITS

To change the weighing units, press **[Unit]** to cycle through the available units. See the Parameter section to enable or disable the weighing units. Once the unit has been selected, the weight will be displayed in the selected unit and a symbol for the weight will be shown.

4.0 PARAMETERS

The balance has 3 parameters that can be set by the user.

FUNCTION	SECTION	DESCRIPTION
Auto Off	See section 5.1	Sets the auto power off function
Backlight	See section 5.2	Sets the backlight OFF BL backlight is off 1 BL backlight is automatic 2 BL backlight is always on
Weighing unit	See section 5.3	Sets the units to be used kg – g – lb – oz – ct – dr – GN – N-tl.t

4.1 AUTO POWER OFF

The auto power off function helps conserve power when using the batteries or AC adapter. The Auto switch-off time may be set up by the user and is the time after a period of inactivity i.e. no weight movement or key presses.

- 1) To set this parameter turn the power off, press and hold the **[Tare]** key then press the **[on/off]** key once, then release the **[Tare]** key.
- 2) The display will show the first function **XX PWR**, where XX is the last setting.
- 3) Press **[Tare]** to select the settings as follows:

Off PWR	Auto power off
10 PWR	10 seconds before the power will switch off
20 PWR	20 seconds before the power will switch off
30 PWR	30 seconds before the power will switch off
40 PWR	40 seconds before the power will switch off
50 PWR	50 seconds before the power will switch off
60 PWR	60 seconds before the power will switch off
70 PWR	70 seconds before the power will switch off
80 PWR	80 seconds before the power will switch off
90 PWR	90 seconds before the power will switch off

- 4) Press the **[Unit]** key to confirm the setting
- 5) To exit turn the balance off and back on again

4.2 SETTING THE BACKLIGHT

The backlight may be enabled or disabled by the user. If the backlight is disabled, the battery life will be greater.

The following settings are available:

1 BL	Sets the backlight to operate automatically when a weight is placed on the balance or a key is pressed.
2 BL	Sets the backlight to be on all the time.
OFF BL	Sets the backlight to be off.

- 1) To set this parameter turn the power off, press and hold the **[Tare]** key then press the **[on/off]** key once, then release the **[Tare]** key.
- 2) The display will show the first function **PWR**
- 3) Press the **[Unit]** key until the display shows **XX BL** where XX is the last setting
- 4) Press **[Tare]** key to select the settings as follows **1 BL - 2 BL – OFF BL**
- 5) Press the **[Unit]** key to confirm the setting
- 6) To exit turn the balance off and back on again

4.3 ENABLING THE WEIGHING UNITS

You can enable and disable the weighing units available to the user when they press the **[Unit]** key as described in section 4.4 *Weighing Units*.

- 1) To set this parameter turn the power off, press and hold the **[Tare]** key then press the **[on/off]** key once, then release the **[Tare]** key.
- 2) The display will show the first function **PWR**
- 3) Press the **[Unit]** key until the display shows you **XX g** where XX is the last setting on or off.
- 4) Press the **[Tare]** key to select **on** or **off**.
- 5) Press the **[Unit]** key to move to the next weighing unit.
- 6) Repeat steps 5 and 6 until you have set all of the weighing units.

7) To exit turn the balance off and back on again

The following table shows the different weighing units which are available to the user and the conversion factors for each.

Name of the Units	Description	Conversion Factor	Display Symbol
Kilograms	A standard metric unit	0.001	Kg
Grams	A standard metric unit	1.0	G
Pounds	Standard weighing unit in UK/USA.	0.002205	Lb
Ounce	Avoirdupois ounce. 16 ounces make a pound.	0.03528	OZ
Carat	Used for weighing jewelry and gems, etc.	5.0	ct
Dram	Avoirdupois unit there are 16 DR in an ounce.	0.564383	DR
Grains	A basic weighing unit in the imperial system. Used to weigh gun powder.	15.432	GN
Newtons	Used to measure force	0.009808	N
Taiwanese tael	Used to weigh coral, pearls etc.	0.026666	TL.t

5.0 CALIBRATION

Calibration may be required when the balance is initially installed or moved to a new location. Over time and use, mechanical deviations may occur so it is recommended that you calibrate your balance regularly for peak performance.

Before calibrating you should make sure you have the correct weights. The weights should be known to an accuracy that is appropriate for the balance being calibrated, for example, OIML Class M1 type or ASTM E617 Class 4. If you do not have the correct weights do not attempt calibration.

Model	CQT 202	CQT 251	CQT 601	CQT 1501	CQT 2601	CQT 2000	CQT 5000
Calibration Weight	100g Or 200g	100g Or 200g	200g Or 400g Or 600g	500g Or 1000g Or 1500g	1000g Or 2000g	1000g Or 2000g	1000g Or 3000g or 5000g

- 1) To calibrate the balance apply power and switch the balance on, whilst the display is cycling through its test routine press the **[Tare]** and **[Unit]** keys at the same time, then release after 1 second .
- 2) The display will show **UnLOAD** remove any objects from the pan.
- 3) Press the **[Tare]** key to enter a zero value.
- 4) The value last used for calibration will be displayed (see above table). To select a different calibration weight, press the **[Unit]** key.
- 5) Once you have selected the calibration weight to be used press the **[Tare]** key.
- 6) **LOAD** will be displayed, place the calibration weight on the pan.
- 7) Once the stable sign is shown press the **[Tare]** key.
- 8) If the weight is within 5% of the last calibration value the display will show **PASS** and exit the calibration mode. If the calibration is not successful the display will show **FAIL** and exit the calibration mode, if the calibration fails try it again.

6.0 TROUBLE SHOOTING

6.1 ERROR MESSAGES

If an error message is shown, repeat the step that caused the message. If the error message is still shown then contact your dealer for support.

ERROR CODE	DESCRIPTION	POSSIBLE CAUSES	Solutions
ADO	A/D Value too high.	Weight on the pan when turning on. Improper calibration of the balance. Damaged load cell. Damaged Electronics.	Remove any weight from the stainless steel pan. Recalibrate.
ADL	A/D Value too low.	Pan is not installed when turning on. Calibration not correct. Damaged load cell.	Install pan and power back on. Recalibrate.
-----	A/D count is not correct when turning the balance on.	Load cell damaged. Electronics damaged.	Remove any weight from the stainless steel pan and try rebooting. Try calibrating the balance.
Unit-E	Unit error.		
	Low battery indicator.	Batteries may be flat.	Charge the battery.
FAIL	Calibration failure.	Incorrect mass used to calibrate. The user calibration is not within 5% of factory calibration. Possible damaged to loadcell.	Try to recalibrate, check that the weight used to calibrate matches that of the value of the balance.
	Unstable – machine cannot get a stable reading.	Possible damage to the Loadcell.	Make sure the balance is on a flat surface and away from vibration.
	No Power when turning on.	Battery may be flat. AC adapter may not be working.	Change the batteries. Or use the AC adapter

6.2 REPLACEMENT PARTS AND ACCESSORIES

If you need to order any spare parts and accessories, contact your supplier or Adam Equipment. A partial list of the more common items follows:

Part Number	Description
7.00.4.0.0023	POWER SUPPLY STANDARD MODEL 12Vac 150ma- UK
7.00.4.0.0024	POWER SUPPLY STANDARD MODEL 12Vac 150ma- USA
7.00.4.0.0025	POWER SUPPLY STANDARD MODEL 12Vac 150ma- OZ
7.00.4.0.0026	POWER SUPPLY STANDARD MODEL 12Vac 150ma- EURO
7.00.4.0.0027	POWER SUPPLY STANDARD MODEL 12Vac 150ma- SA
3.08.1.2.2009	TOP PAN 120mm
3.08.1.2.2011	TOP PAN 145mm
3.08.2.3.2031	BREEZE SHIELD WITH LID
3.08.2.3.2033	IN USE COVER
7.00.1.0.0046	SECURITY LOCK AND CABLE

7.0 SPECIFICATIONS

Model #	CQT-202	CQT- 251	CQT-601	CQT-1501	CQT-2601	CQT-2000	CQT-5000
Maximum Capacity	200g	250g	600g	1500g	2600g	2000g	5000g
Readability	0.01g	0.1g	0.1g	0.1g	0.1g	1g	1g
Resolution	1:20000	1:2500	1:6000	1:15000	1:26000	1:2000	1:5000
Repeatability (Std Dev)	0.02g	0.1g	0.1g	0.2g	0.2g	1g	1g
Linearity ±	0.02g	0.1g	0.1g	0.2g	0.2g	1g	1g
Units of Measure	kg / g / lb / oz / ct / dr / GN / N/tl.t						
Stabilisation Time	3 seconds	2 seconds		3 seconds		2 seconds	
Operating Temperature	0°C to 40°C 32°F to 104°F						
Power Supply	12VAC @ 150mA adapter or 6x AA batteries						
Calibration	Push button calibration using external mass						
Calibration Mass	200g	250g	600g	1500g	2000g	2000g	5000g
Display	6 digit LCD, 18mm digits, with backlight						
Draft shield (diameter x h)	132mm ø x 82mm (5.2" ø x 3.2")				N/A		
Balance Housing	ABS Plastic						
Pan Size	120mm ø (4.7" ø)				145mm ø (5.7" ø)		
Overall Dimensions (w x d x h)	173 x 255 x 86mm (6.8" x 10" x 3.4") Without draft shield						
Net Weight	820g (1.8lb)						

8.0 WARRANTY STATEMENT

Adam Equipment offers Limited Warranty (Parts and Labour) for the components failed due to defects in materials or workmanship. Warranty starts from the date of delivery.

During the warranty period, should any repairs be necessary, the purchaser must inform its supplier or Adam Equipment Company. The company or its authorised Technician reserves the right to repair or replace the components at any of its workshops depending on the severity of the problems. However, any freight involved in sending the faulty units or parts to the service centre should be borne by the purchaser.

The warranty will cease to operate if the equipment is not returned in the original packaging and with correct documentation for a claim to be processed. All claims are at the sole discretion of Adam Equipment.

This warranty does not cover equipment where defects or poor performance is due to misuse, accidental damage, exposure to radioactive or corrosive materials, negligence, faulty installation, unauthorised modifications or attempted repair or failure to observe the requirements and recommendations as given in this User Manual. Additionally rechargeable batteries (where supplied) are not covered under warranty.

Repairs carried out under the warranty does not extend the warranty period. Components removed during the warranty repairs become the company property.

The statutory right of the purchaser is not affected by this warranty. The terms of this warranty is governed by the UK law. For complete details on Warranty Information, see the terms and conditions of sale available on our web-site.



Manufacturer's Declaration of Conformity

This product has been manufactured in accordance with the harmonised European standards, following the provisions of the below stated directives:

Electro Magnetic Compatibility Directive 2004/108/EC

Low Voltage Directive 2006/95/EC

Adam Equipment Co. Ltd.
Maidstone Road, Kingston,
Milton Keynes,
MK10 0BD United Kingdom

FCC COMPLIANCE

This equipment has been tested and found to comply with the limits for a Class A digital device, pursuant to Part 15 of the FCC Rules. These limits are designed to provide reasonable protection against harmful interference when the equipment is operated in a commercial environment. The equipment generates, uses, and can radiate radio frequency energy and, if not installed and used in accordance with the instruction manual, may cause harmful interference to radio communications. Operation of this equipment in a residential area is likely to cause harmful interference in which case the user will be required to correct the interference at his own expense.

Shielded interconnect cables must be employed with this equipment to insure compliance with the pertinent RF emission limits governing this device.

Changes or modifications not expressly approved by Adam Equipment could void the user's authority to operate the equipment.

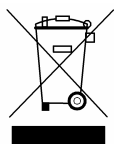

Sealed Lead Acid
Battery
Must be recycled
Properly

WEEE COMPLIANCE

Any Electrical or Electronic Equipment (EEE) component or assembly of parts intended to be incorporated into EEE devices as defined by European Directive 2002/95/EEC must be recycled or disposed using techniques that do not introduce hazardous substances harmful to our health or the environment as listed in Directive 2002/95/EC or amending legislation. Battery disposal in Landfill Sites is more regulated since July 2002 by regulation 9 of the Landfill (England and Wales) Regulations 2002 and Hazardous Waste Regulations 2005. Battery recycling has become topical and the Waste Electrical and Electronic Equipment (WEEE) Regulations are set to impose targets for recycling.

ADAM EQUIPMENT is an ISO 9001:2008 certified global company with more than 35 years experience in the production and sale of electronic weighing equipment.

Adam products are predominantly designed for the Laboratory, Educational, Health and Fitness, retail and Industrial Segments. The product range can be described as follows:

- Analytical and Precision Balances
- Compact and Portable Balances
- High Capacity Balances
- Moisture analysers / balances
- Mechanical Scales
- Counting Scales
- Digital Weighing/Check-weighing Scales
- High performance Platform Scales
- Crane scales
- Health and Fitness Scales
- Retail Scales for Price computing

For a complete listing of all Adam products visit our website at www.adamequipment.com

© Copyright by Adam Equipment Co. Ltd. All rights reserved. No part of this publication may be reprinted or translated in any form or by any means without the prior permission of Adam Equipment.

Adam Equipment reserves the right to make changes to the technology, features, specifications and design of the equipment without notice.