

leXsolar-Wind Ready-to-go

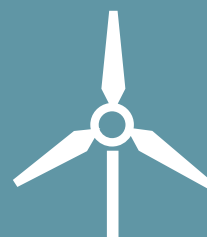
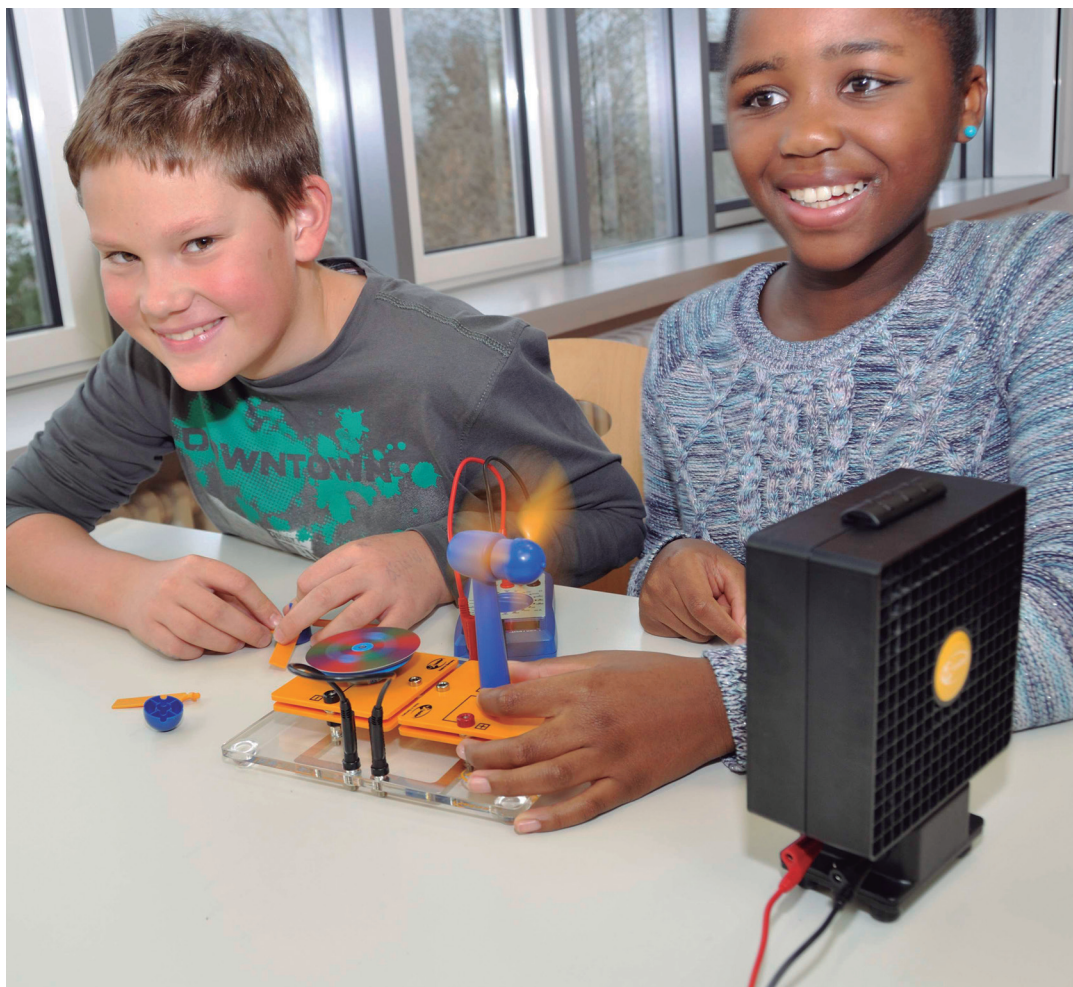

Student's Manual

Layout diagram leXsolar-Wind Ready-to-go

Item-No.1405

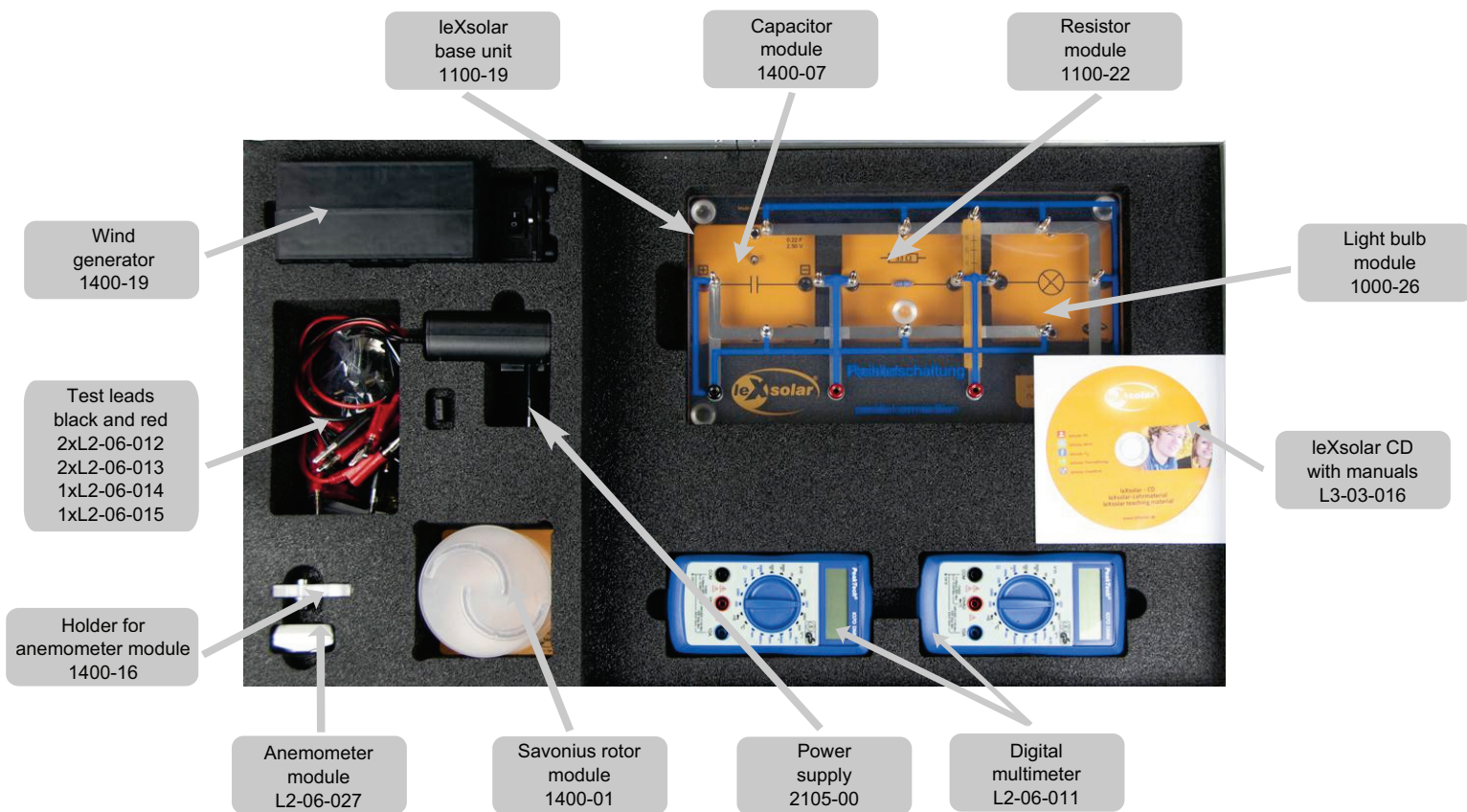

Layout diagram leXsolar-Wind Ready-to-go

Item-No.1405

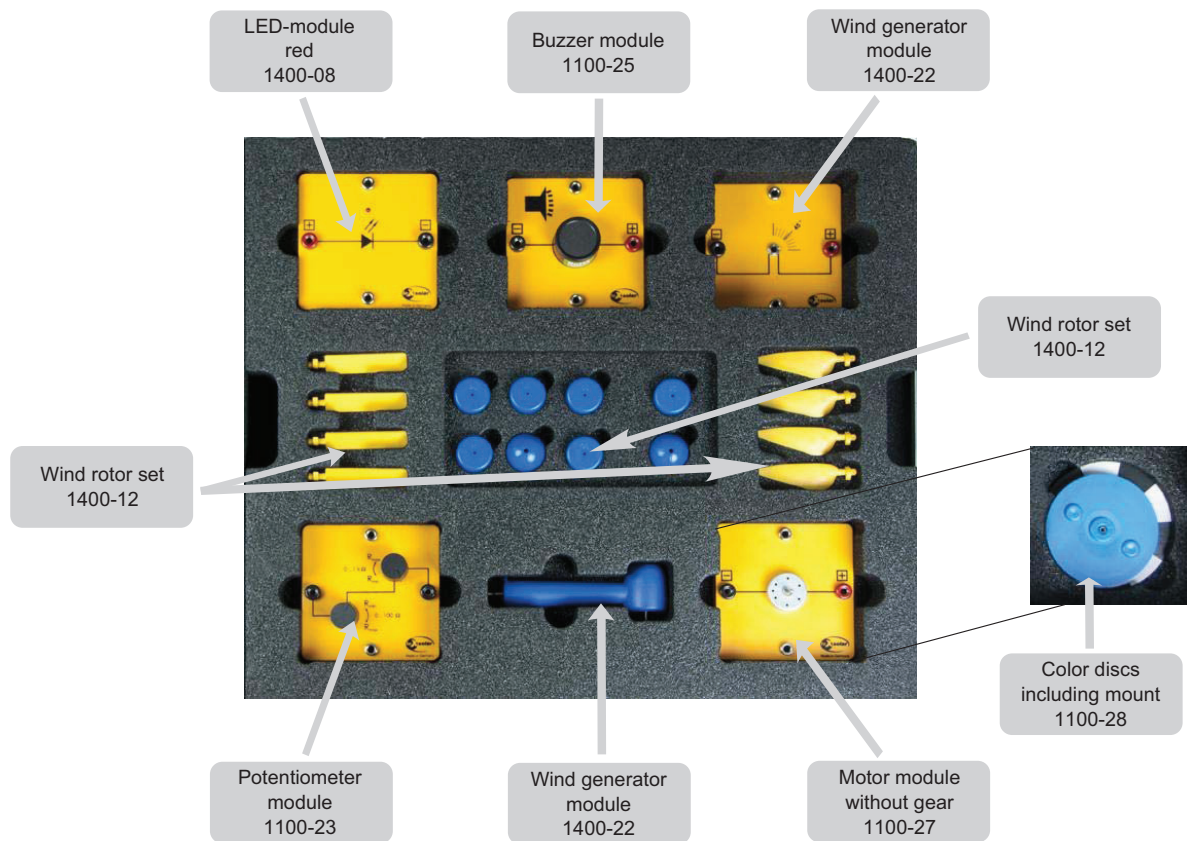

leXsolar-Wind Ready-to-go

Student`s Manual

Contents

This booklet contains instructions for experiments as well as the corresponding templates for the evaluation of the following experiments:

1.1 Changing wind speed by changing the distance (phenomenologically)	11
1.2 Changing wind speed by changing the distance (voltage measurement).....	12
1.3 Changing wind speed by changing the distance (output measurement)	14
2.1 Start-up wind speed at a wind turbine.....	16
2.2 Comparison of the start-up wind speed of a Savonius and a three-blade rotor.....	18
3.1 Change the turbine voltage by connecting a consumer (with resistance).....	20
3.2 Changing the turbine voltage by connecting several consumers.....	22
4. Examine the wind speed behind the rotor	24
5.1 Energy balance sheet at a wind turbine	26
5.2 Calculating the efficiency of a wind turbine.....	28
6. Storing electric energy	30
7.1 Energy conversion in a wind turbine	32
7.2 Examine color wheels using a wind turbine	33
8.1 Comparison of a Savonius rotor and a three-blade rotor (phenomenologically)	35
8.2 Comparison of a Savonius rotor and a three-blade rotor (voltage measurement).....	37
8.3 Comparison of a Savonius rotor and a three-blade rotor (output measurement)	39
9.1 Comparison of two, three and four-blade rotors (phenomenologically)	42
9.2 Comparison of two, three and four-blade rotors (voltage measurement)	44
9.3 Comparison of two, three and four-blade rotors (output measurement).....	46
10 Characteristic curves of a wind turbine	49
11.1 Influence of the wind direction (phenomenologically)	51
11.2 Influence of the wind direction (voltage measurement).....	52
11.3 Influence of the wind direction (output measurement).....	54
12.1 Influence of the rotor blade pitch (phenomenologically)	56
12.2 Influence of the rotor blade pitch (voltage measurement).....	57
12.3 Influence of the rotor blade pitch (output measurement).....	59
12.4 Influence of the rotor blade pitch on the start up speed of a wind turbine	61

13.1 Influence of the blade shape (phenomenologically)	64
13.2 Influence of the blade shape (voltage measurement)	65
13.3 Influence of the blade shape (output measurement).....	66

Pages 5 to 10 contain more detailed explanations of the instructions and execution of experiments.



1.1 Influence of the wind speed on a wind turbine (phenomenologically)

Exercise

Examine the brightness of a light-emitting diode, which is powered by a wind turbine.

Experimental setup

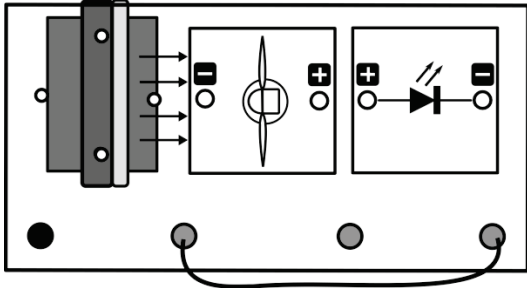

Equipment needed

- leXsolar main board
- Wind machine with power supply (variable)
- Wind turbine module (with three rotor blades, 25°, optimized profile)
- LED module
- Cable

Preliminary remark

In this experiment you can examine how electricity generated by the wind turbine changes when the wind speed changes. The variation of wind speed is done by changing the voltage at the wind machine.

Execution

1. Set the experiment up according to the experiment set-up.
2. Change the voltage at the wind machine with the variable power supply. Start with 6V.
3. Observe how the brightness of the light-emitting diode changes and enter your observations in the table. Color in the corresponding number of fields.

Evaluation

Voltage at the wind machine	6V	7,5V	9V	12V	Example																										
The LED lights up...	<table border="1" style="width: 100%; height: 100%;"> <tr><td> </td></tr> <tr><td> </td></tr> <tr><td> </td></tr> <tr><td> </td></tr> <tr><td> </td></tr> </table>						<table border="1" style="width: 100%; height: 100%;"> <tr><td> </td></tr> <tr><td> </td></tr> <tr><td> </td></tr> <tr><td> </td></tr> <tr><td> </td></tr> </table>						<table border="1" style="width: 100%; height: 100%;"> <tr><td> </td></tr> <tr><td> </td></tr> <tr><td> </td></tr> <tr><td> </td></tr> <tr><td> </td></tr> </table>						<table border="1" style="width: 100%; height: 100%;"> <tr><td> </td></tr> <tr><td> </td></tr> <tr><td> </td></tr> <tr><td> </td></tr> <tr><td> </td></tr> </table>						<table style="width: 100%;"> <tr> <td style="width: 50%;"></td> <td>bright</td> </tr> <tr> <td></td> <td>weak</td> </tr> <tr> <td></td> <td>not at all</td> </tr> </table>		bright		weak		not at all
	bright																														
	weak																														
	not at all																														

Now complete the sentences:

With a lower voltage at the wind machine, the LED is _____.

The _____ the wind speed, the brighter the LED.



7.1 Energy conversion in a wind turbine

Exercise

Use a wind turbine to light up a light bulb and to blow a horn.

Experimental setup

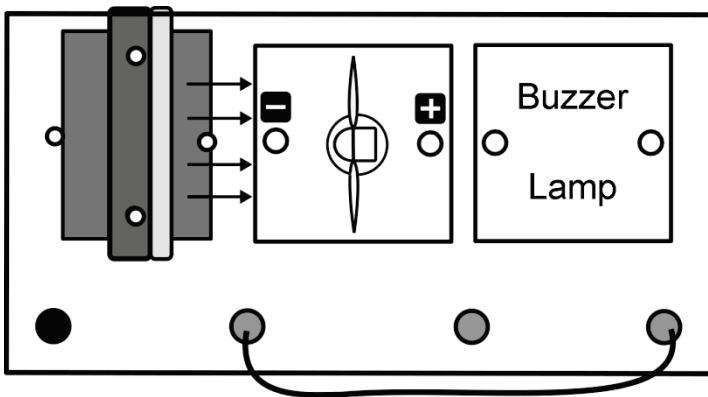

Equipment needed

- leXsolar main board
- Wind machine module with power supply
- Wind turbine module (with three rotor blades, 25°, optimized profile)
- Light bulb module
- Horn module
- Cable

Execution

1. Set the experiment up according to the experiment set-up with the horn (regarding the polarity!)
2. Set the wind machine to 12V and start the power supply.
3. Then switch off the power supply and replace the horn with the light bulb. Write down your observation.

Observation

Evaluation

Complete the following text.

Wind is _____ of air masses. Air consists of particles. The air particles have kinetic _____. It flows past the _____ of the wind turbine. The wind rotor extracts energy from the wind and converts it into _____ movement. This generates voltage in the _____. This _____ the light bulb and lets _____ make a sound.



13.1 Influence of the blade shape (phenomenologically)

Exercise

Examine the brightness of a light-emitting diode, which is powered by a wind turbine with different shaped rotor blades.

Experimental setup

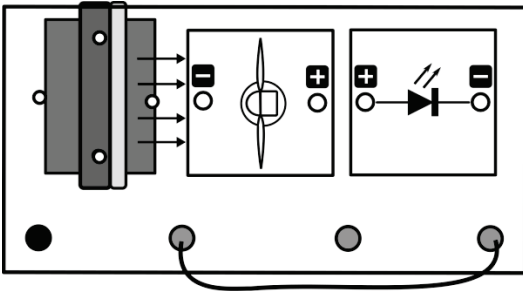

Equipment needed

- leXsolar main board
- Wind machine module with power supply
- Wind turbine module (with three rotor blades, 25°, optimized and flat profile)
- LED module
- Cable

Execution

1. Set the experiment up according to the experiment set-up.
2. Put the 3-blade rotor with the optimized profile on the wind turbine and turn the wind machine on (exciter voltage 9V).
3. Observe how the brightness of the light-emitting diode changes and write down your observations.
4. Repeat the measurement with the rotor blade with flat profile.

Evaluation

1. Which blade shape illuminates the LED stronger?
2. Examine the shape of the two rotor blades closer. What are the differences?
3. Do you know any examples where the flat profile is used?

1. _____

2. _____

3. _____

leXsolar GmbH
Strehleener Straße 12-14
01069 Dresden / Germany

Telefon: +49 (0) 351 - 47 96 56 0
Fax: +49 (0) 351 - 47 96 56 - 111
E-Mail: info@lexsolar.de
Web: www.lexsolar.de